

POWTRONICS

Vibrators and Powder Equipment General Catalog



URAS TECHNO CO., LTD.

<http://www.uras-techno.co.jp/en>

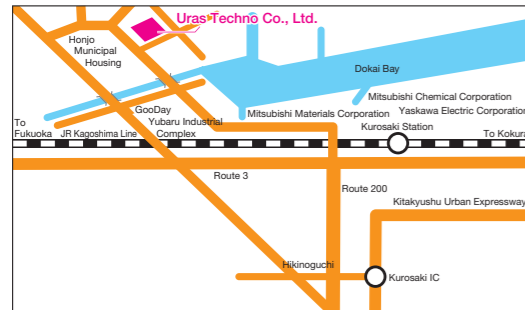

Head Office & Kyushu Sales Office

1-1 Dohoku-machi, Yahatanishi-ku, Kitakyushu City,
Fukuoka 807-0811, Japan
TEL: +81-93-693-8301 FAX: +81-93-693-8306
E-mail: utc_kyushu@uras-techno.co.jp



Tokyo Branch Office & Overseas Sales Department

2F Senbo Building, 2-16-9 Uchikanda, Chiyoda-ku,
Tokyo 101-0047, Japan
TEL: +81-3-3254-6101 FAX: +81-3-3254-6105
E-mail: utc_tokyo@uras-techno.co.jp

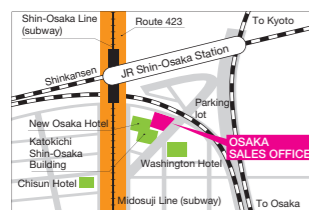

Osaka Branch Office

4F Recruit Shin-Osaka Building, 5-14-22 Nishinakajima,
Yodogawa-ku, Osaka City 532-0011, Japan
TEL: +81-6-6390-0834 FAX: +81-6-6390-0836
E-mail: utc_osaka@uras-techno.co.jp



Nagoya Branch Office

2F Minami Sakae Building, 1-22-16 Sakae, Naka-ku,
Nagoya City 460-0008, Japan
TEL: +81-52-219-5580 FAX: +81-52-219-5581
E-mail: utc_nagoya@uras-techno.co.jp

Powder Engineering Center

Murakami Seiki Mfg. Co., Ltd.
1-1 Dohoku-machi, Yahatanishi-ku, Kitakyushu City, Fukuoka 807-0811, Japan
TEL: +81-93-601-1037 FAX: +81-93-601-1041

Vibration Equipment Powder Engineering Center

Daito Vibration Engineering Co., Ltd.
5-9-18 Shioe, Amagasaki City, Hyogo 661-0976, Japan
TEL: +81-6-6422-2041 FAX: +81-6-6422-2047
Chiba Doryoko Co., Ltd.
49-2 Chigusa-cho, Hanamigawa-ku, Chiba 262-0012, Japan
TEL: +81-43-259-1035 FAX: +81-43-250-0821



Safety Precautions

For ease of viewing, products in this catalog are photographed without safety devices or equipment, such as safety fences, required by laws/regulations. Also, illustrations and sketches within may not completely represent the products. Before using any product, thoroughly read the instruction manual and other reference documents.

Note: The contents of this catalog are current as of August 2012. Specifications, appearance, and other factors are subject to change without notice for product improvements.

UTC-2E Ver1.0 2013.03.05



URAS TECHNO CO., LTD.

Creating a New World with Vibration Technology

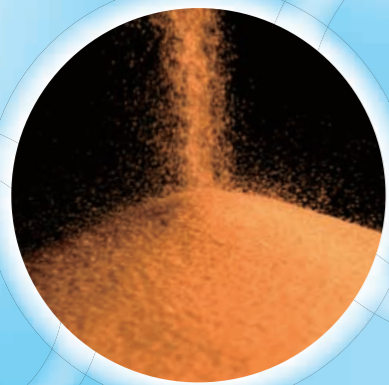

Shoji Hashimoto
President and Chief Executive
Officer

President's Message

Uras Techno aims to provide

- Solutions that use our matchless technologies in vibrators and powder equipment
- Unique powder and granular material handling equipment designed with our vibration technology
- Powder and granular material systems in which powders and control technologies are integrated.

We are experiencing a shift from mass consumption and disposability to an age where importance is placed on people, resources and the earth. We work with our customers to construct solutions that meet their needs in this age of new values.

As a source of creative technology, Uras Techno seeks to support customers with vibration and powder technologies.

Businesses

1. Sales, import and export of vibrators and powder equipment
2. Design and construction of powder and granular material production and processing equipment

Profile

Established: February 9, 2000

Capital: 50 million yen (authorized capital: 200 million yen)

Head office: 1-1 Dohoku-machi, Yahatanishi-ku, Kitakyushu City, Fukuoka 807-0811 Japan

Directors: Chairman & CEO Hiroshi Murakami
President & CEO Shoji Hashimoto
Director Yoshiro Hanasaki
Director Harumi Gonda

Organization Chart

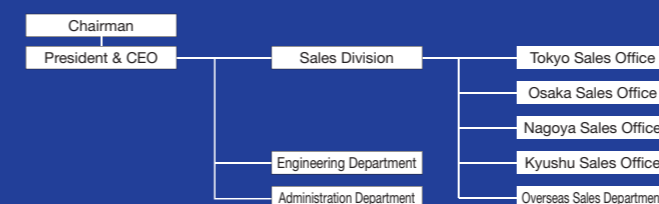

Contents

- Vibrators 6
- Feeders and Conveyors 8
- Screeners 10
- Classifiers and Mills 12
- Filling Machines and Scales..... 14
- Other Products..... 16
- System Application Examples..... 18
- Guide to Sample Testing 19

POWTRONICS Responds to Customer

Needs with System Solutions

Vibrators



URAS Vibrators



Electromagnetic Unit



Air Vibrators

Applied Vibration Technologies

Feeding



Conveying

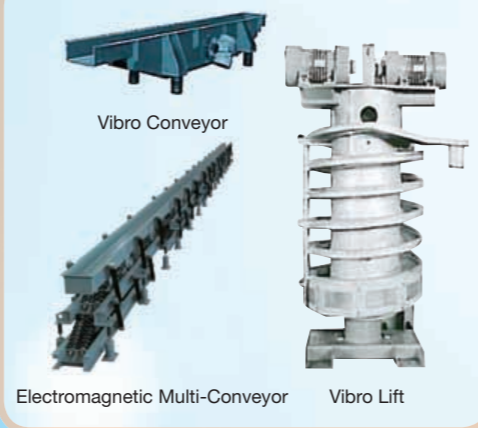

Screening



Powder Processing Technologies

Classification



Milling



Conveying, Filling and Handling



Systems

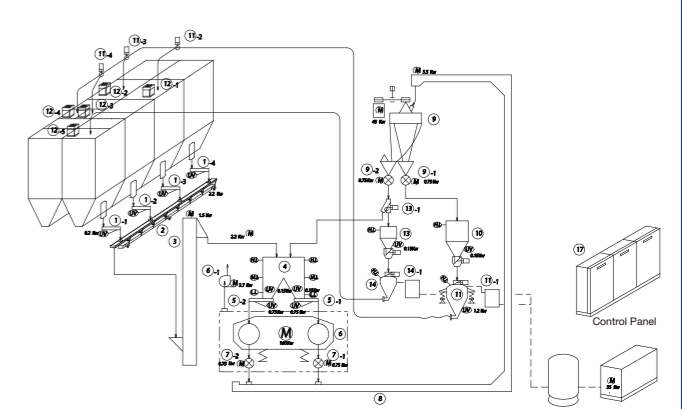

Milling and Separating System Flow

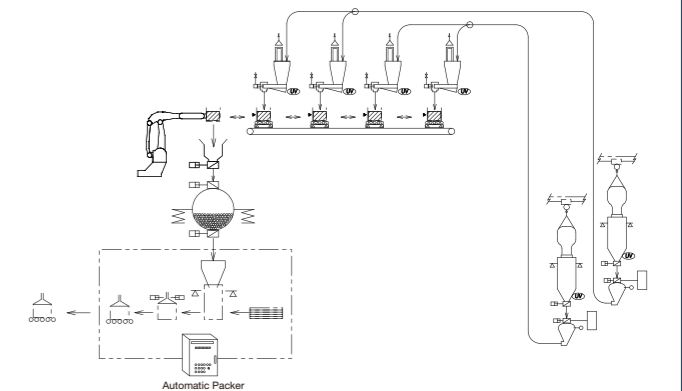

Weighing, Mixing and Packing System Flow

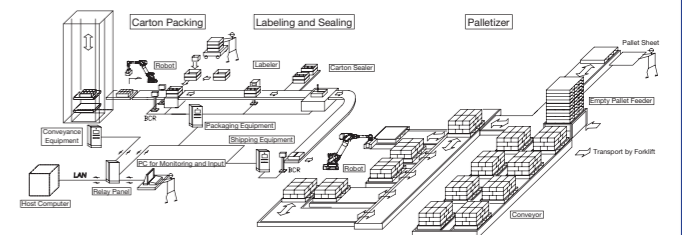

Carton Packing and Palletizing System Flow

POWTRONICS

POWTRONICS (Power + Electronics), proposed by Uras Techno, is a powder and granular material system with integrated powder and control technologies.

Vibrators

The Global Standard in Vibrators

URAS



URAS vibrators are motor-driven high performance vibration generators.

Since their introduction to the market in 1959, URAS vibrators have undergone constant evolution, and the number of units delivered has surpassed 80,000. Our vibrators are being used in various industries around the world, particularly in materials industries.

We have an extensive lineup of models to meet the diverse needs of our customers. Long service life, ease of maintenance and high reliability are assured.

Our extensive track record and reputation over the years have proven the performance of our products as being a true global standard.

The URAS quality delivered to you will make you realize that machines encompass change.

Standard URAS KEE



Applications

- Hopper clogging prevention
- Vibration machines, etc.

Standard Single-Phase URAS SEE



Applications

- Hopper clogging prevention
- Vibration machines, etc.

Safety-Enhanced Explosion-Proof KZE



Applications

- Can be used in Class II hazardous locations where a hazardous atmosphere may be generated.

Features

Certified as explosion-protected electrical equipment by the Technology Institution of Industrial Safety

Vertical (Flange Type) KEEV



Applications

- Circular screen
- Barrel finishing machine

Features

With upper and lower weights of different mass attached, this model generates three-dimensional vibrations.

High-Frequency URAS KHE



Applications

- Pouring concrete

Features

Generates vibrations in the range of 100 to 180 Hz.

URAS with Stainless Steel Covers



Applications

- Hopper clogging prevention
- Vibration machines, etc.

Features

With stainless steel covers installed, this model is rust-resistant and enables frequent cleaning.

Pneumatic Series

Turbine Vibrators



Applications

- Food, pharmaceutical processing

Features

- Very small
- Weight: 20g
- Vibration force: 50N
- Oil-free (Made of acetal resin or stainless steel)
- Low noise

Air-Cushioned Model



Applications

- Prevention of material adhesion to hopper and chute walls
- Vibration machines, etc.

Features

Air cushion prevents the piston from directly contacting the frame.

Single Impactor



Applications

- Prevention of material adhesion to hopper and chute walls

Features

Hammers automatically (using compressed air).

Feeders and Conveyors

Vibro Hopper



Features

- Prevents bridging by directly applying vibrations to the baffle.

Specifications

- Vibro Hopper diameter: 400 to 2400 mm

Applications

- Discharging powders and granular materials from a hopper or a silo

Vibro Feeder



Features

- The force-feed construction helps the feeder to prevent material adhesion and load fluctuations

Specifications

- Transport capacity: Up to 5000 t/h

Applications

- Discharging and feeding powders, granular materials and lumpy materials

Electromagnetic Feeder



Features

- Driven by an electromagnet.
- Smooth start and stop operation, with minimized coasting before coming to a full stop.

Specifications

- Feeding capacity: Up to 900 t/h

Applications

- Discharging and feeding powders, granular materials and lumpy materials
- Feeding to scales

Air Feeder

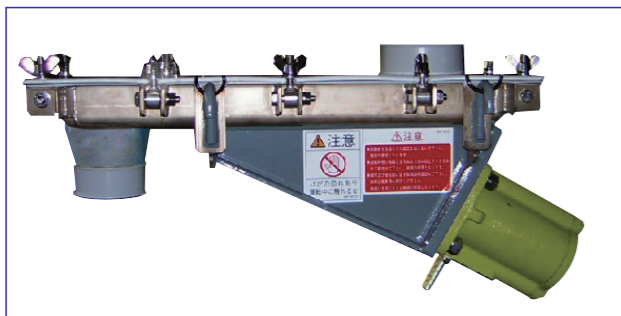

Features

- Pneumatically driven.
- Can be used in locations with explosion-proof requirements.

Specifications

- Feeding capacity: Up to 10 t/h

Applications

- Discharging and feeding powders and granular materials

Vibro Conveyor



Features

- Easy to clean with no transported material falling from the conveyor

Specifications

- Transport capacity: Up to 150 t/h

Applications

- Conveyance, heating and cooling, etc. of powders, granular materials and lumpy materials

Vibro Lift



Features

- Vertical conveyance with a spiral trough

Specifications

- Lifting range: 1000 to 2200 mm

Applications

- Cooling of pellets
- Vertical conveyance of powders and granular materials

Electromagnetic Multi-Conveyor

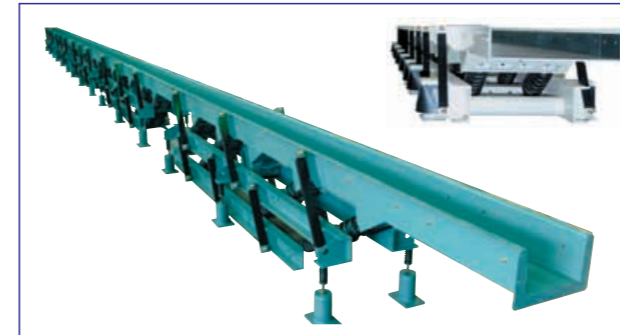

Features

- Applicable to conveyance of long objects (up to 30 m).
- Less vibration transmitted to the floor
- Maintenance-free

Specifications

- Transport capacity: Up to 125 t/h

Applications

- Conveyance of powders, granular materials and lumpy materials

Bowl Feeder



Features

- Hopper and feeder functions in one unit
- Can be used to align materials.

Specifications

- Bowl diameter: 500 to 1500 mm

Applications

- Cleaning of metals, and feeding of short fiber and flake materials
- Aligned feeding of foods, and surface dredging of additives on foods

Screeners

Separators and Applicable Grain Size Ranges

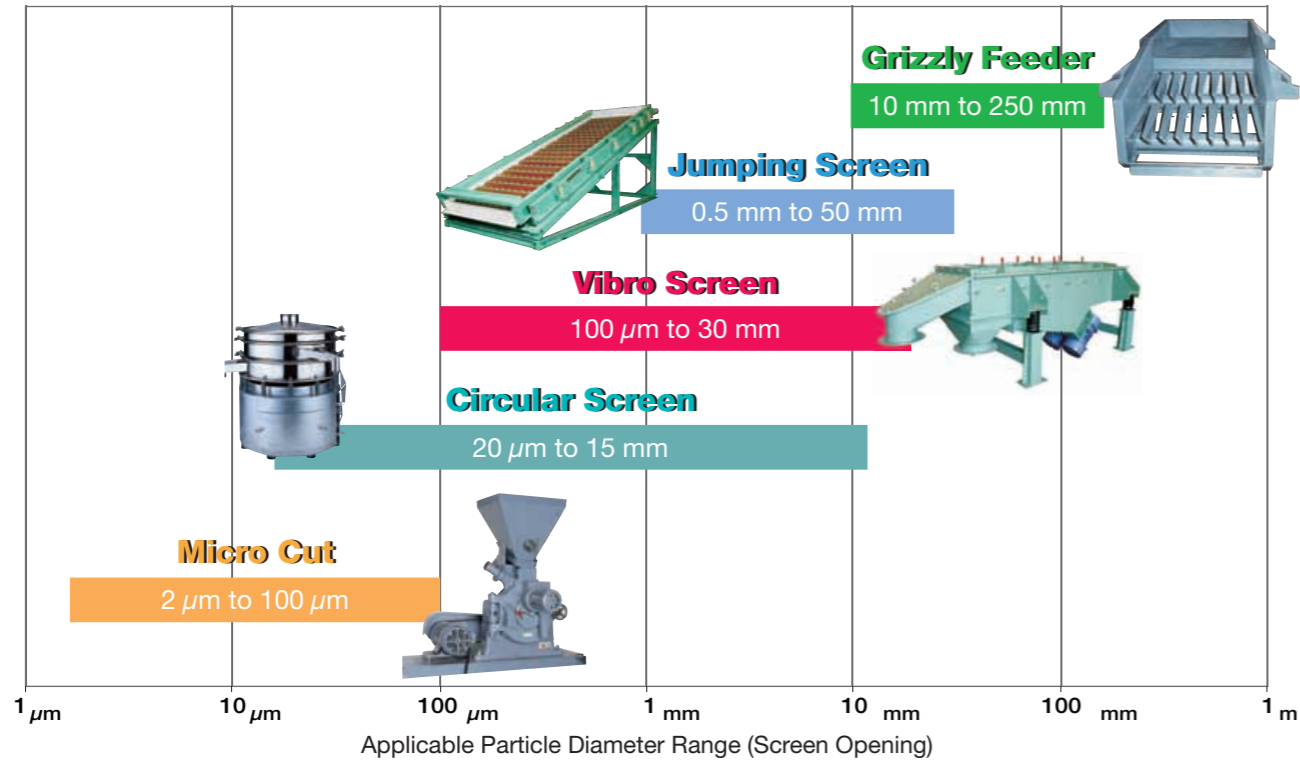

Vibro Shakeout Machine

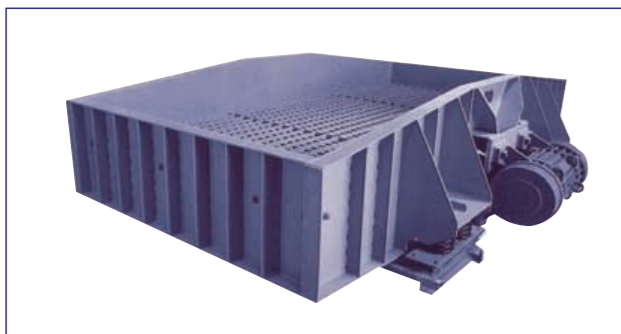

- Features**
- Separates sand from castings with vertical vibrations.
- Specifications**
- Grate dimensions: 100 x 1500 to 2000 x 2500 mm
 - Load capacity: 1000 to 8000 kg (including the grate)
- Applications**
- Shaking sand out of castings

Vibro Grizzly Feeder



- Features**
- Large capacity—suited for screening of materials with large lumps
 - No adhesion of mud or other materials
- Specifications**
- Processing capacity: Up to 600 t/h
 - Trough width: 600 to 2400 mm
- Applications**
- Screening of raw stones

Jumping Screen (Flip-Flow Screen)

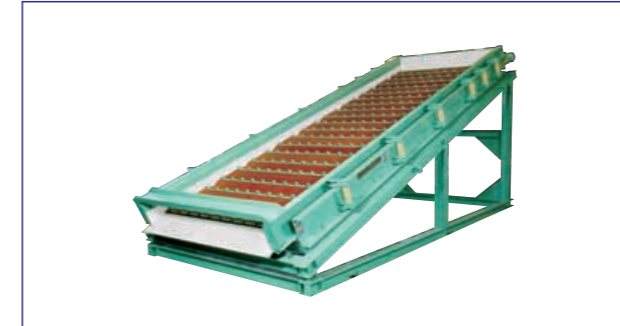

* Jumping Screen is on sale only in Japan.

- Features**
- No clogging—even moist and adhesive materials can be stably and efficiently screened.
- Specifications**
- Screen area: 1 to 26.5 m² --- (single or double deck)
- Applications**
- Sieving of recovered casting sand, muck, breeze, coal, plasterboard, crushed ore, scrap from demolished houses, and shredder residue

Vibro Screen



- Features**
- User can choose from screen and construction type selections in accordance with the characteristics of the material to be screened
- Specifications**
- Effective screen area: 0.31 to 9.4 m²/deck
 - Number of decks: From 1 to 3 decks
- Applications**
- Screening of mineral products, chemical products, resins, pharmaceutical products, and other materials.
 - Dehydration of materials

R-Type Screen (Circular Screen)



- Features**
- Repeated batch operations with counterclockwise turns (when screening) and clockwise turns (when discharging) enable a 95% or greater recovery rate of fine powder under the screen, a rate that was formerly difficult to obtain.
- Specifications**
- Screen diameter: 500, 800, 1000, 1200 and 1500 mm
 - Number of decks: From 1 to 3 decks
 - Screen opening: 20 to 15 mm
- Applications**
- Screening of iron oxide, solder powder, alumina, titanium oxide, carbon powder, tea leaves, etc.

Bull-Top Separator



- Features**
- Disintegrates and screens casting sand (residual slag) and similar materials.
- Specifications**
- Processing capacity: Up to 1000 kg/h
- Applications**
- Residual slag for recycling, etc.

Micro Cut Air Classifiers

- Micro Cut can classify larger volumes of microscopic particle sizes than screen separators can.

Model: YACA-132H



Features

- Classification diameter range can be set from 2 to 15 μm .
- Clear particle size distribution can be achieved.

Specifications

- Processing capacity: Up to 50 kg/h

Applications

- Toner, carbon, ferrite, silica, talc, alumina, activated coal, etc.

Models: YACA-400H, 400HS, and 400HU



Features

- Classification diameter range can be set at 3.5 to 50 μm for the smallest range.
- Clear particle size distribution can be achieved.

Specifications

- Processing capacity: Up to 2500 kg/h

Applications

- Toner, carbon, ferrite, calcium carbonate, silica, talc, alumina, activated coal, etc.

Models: YACA-400V, 600V, 1000V, and 1350V



Features

- Classification diameter range can be set from 8 to 100 μm .
- Easy to operate, and saves installation space with the built-in micro-powder collector.

Specifications

- Processing capacity: Up to 20 t/h

Applications

- Toner, carbon, ferrite, calcium carbonate, silica, talc, alumina, activated carbon, etc.

Internal Structure (Air Flow Diagram)

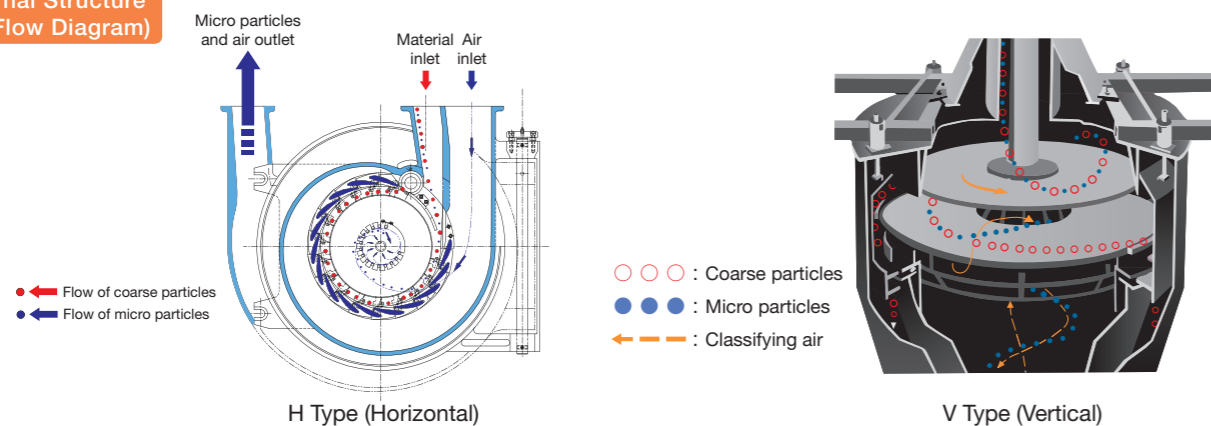

Milling Machines (Vibro Mill)

- These machines apply circular vibrations to mill, mix, and disperse any kind of powder or granular material, and to polish their surfaces.

Continuous Vibro Mill



Features

- Applicable to both wet and dry milling, continuously mills at a high speed.

Specifications

- Drum capacity: 20 to 2000 ℓ
- Processing capacity: Up to 40000 kg/h

Applications

- Alumina, lime, ferrite, carbon, pharmaceutical products, incinerated residue, coke, blast-furnace slag, waste concrete aggregate for recycling, etc.

Reverse Batch Vibro Mill

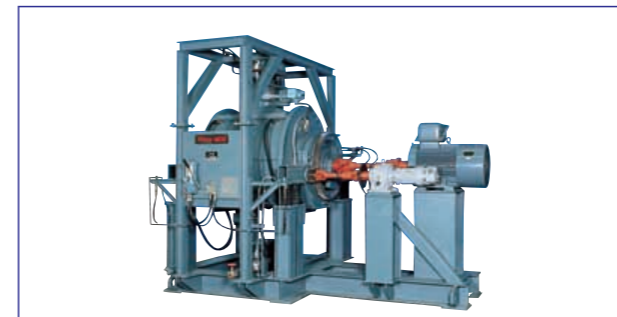

Features

- Fully automatic operation of material loading and discharging
- Complete discharge within a short period of time

Specifications

- Drum capacity: 100 to 1000 ℓ
- Feed capacity: Up to 300 ℓ

Applications

- Alumina, fine ceramics, ferrite, carbon, etc.

Horizontal Batch Vibro Mill

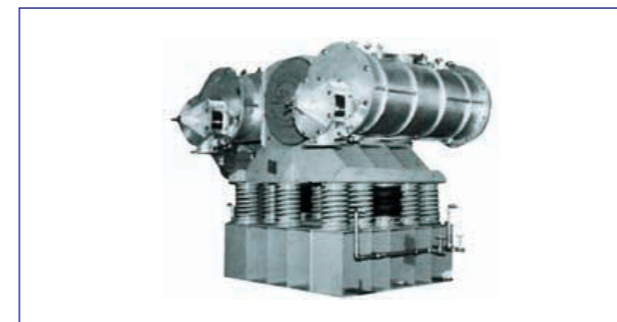

Features

- Ideal for micro-milling

Specifications

- Drum capacity: 20 to 2000 ℓ
- Feed capacity: Up to 600 ℓ

Applications

- Alumina, ferrite, carbon, pharmaceutical products, metal powder, etc.

Vibro Pot



Features

- Ideal for small sample production runs of materials ranging from granular materials to super-micro particles

Specifications

- Drum capacity: 1.2 ℓ x 2 to 3 ℓ x 2

Applications

- Production of sample quantities for analysis and research

Filling Machines (Vibrating Tables)

Vibro Packer



Features

- Pours and compacts powder and granular materials at a high speed using one or multiple units of the URAS vibrator.

Specifications

- Vibration acceleration: 20 to 70 m/s² (2 to 7 G)

Applications

- Pouring casting sand into molds, and removing air from secondary concrete products
- Filling flexible containers
- Bag aligning

Electromagnetic Packer



Features

- A vibrating table using an electromagnet drive
- Easy to adjust vibration acceleration

Specifications

- Vibration acceleration: Up to 110 m/s² (11G)

Applications

- Filling of carbon, magnetic materials, fine ceramics, etc.

Example of Filling and Weighing Equipment

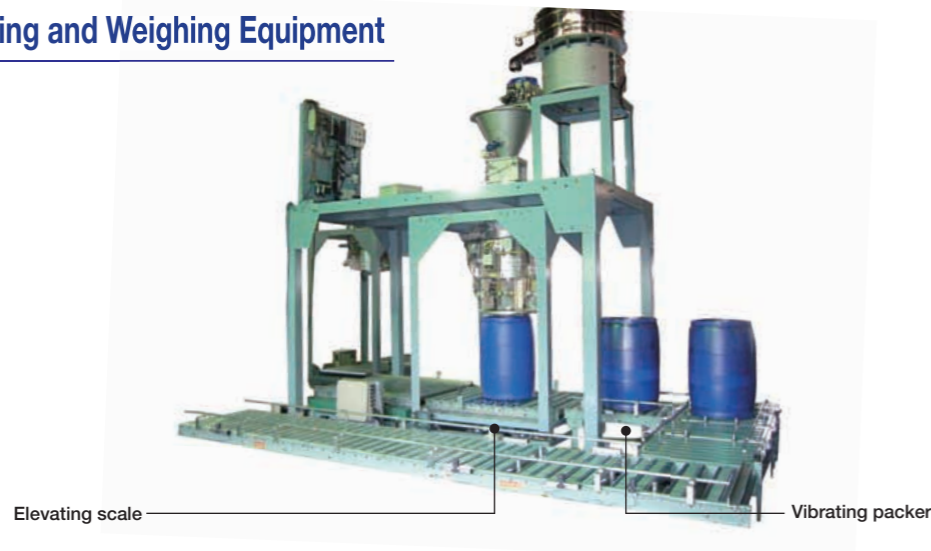

Scales

Hopper Scale



Features

- A load cell-based weighing hopper and a control system.

Specifications

- Rated capacity: 5 to 2000 kg/h

Applications

- Measurement of powders and granular materials

Container Bag Auto-Weighing and Filling Equipment



Features

- An automatic container bag weighing and filling system. Gross weighing type with load cell-based platform scale.

Specifications

- Weighing range: 200 to 2000 kg
- Capacity: 10 to 30 bags/h

Applications

- Weighing and filling products in container bags

Gross-Type Packer Scale



Features

- A gross weighing scale for powder and granular products
- The feeder may be cut gate, vibrating feeder, screw feeder or another. In some applications, this scale is used with a combination of different feeder types.

Specifications

- Weighing range: 5 to 30 kg
- Capacity: Up to 180 bags/h

Applications

- Weighing and pouring material into open bags

Automatic Corrugated Box Packing Machine



Features

- A gross weighing scale for powder and granular products
- The feeder may be cut gate, vibrating feeder, screw feeder or another. In some applications, this scale is used with a combination of different feeder types.

Specifications

- Weighing range: 5 to 30 kg
- Capacity: Up to 180 cartons/h

Applications

- Weighing and pouring material into corrugated boxes

Other Products

Step Flow

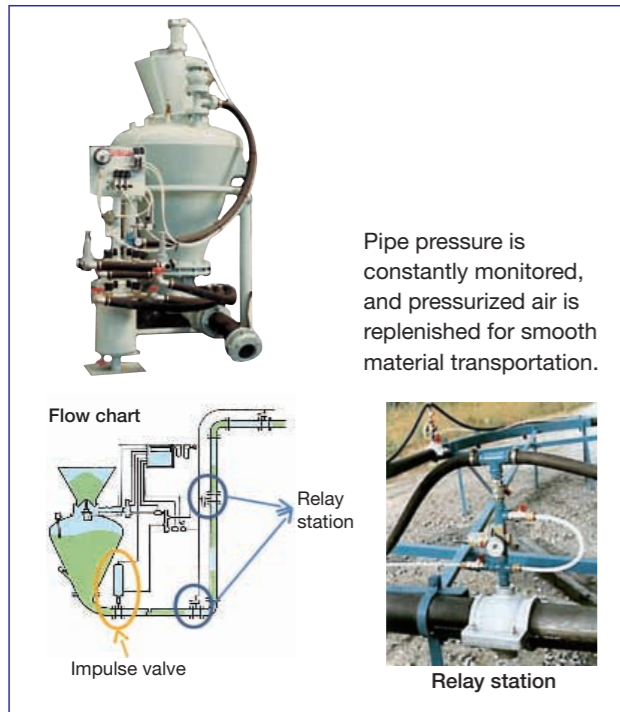

Pipe pressure is constantly monitored, and pressurized air is replenished for smooth material transportation.

Features

- Plug-flow dense-phase pneumatic conveying equipment
- Powder or granular material in the pressurized tank is pushed out in a densely filled state, without fluidization, and transported in the flow of plugs formed by the impulse valve.

Specifications

- Pressurized tank capacity: 30 to 5000 ℓ
- Transport pipe diameter: 50 to 250 A
- Transport distance (actual value): 300-m horizontally, 54-m vertically

Applications

- High-density materials: Metal powder, ore powder, etc.
- High-abrasive materials: Fused silica, casting sand, glass powder
- Fragile materials: Pelletized carbon, activated carbon, salt, etc.
- Highly-adhesive materials: Coal (10% moisture content), gypsum

Caliper Brake

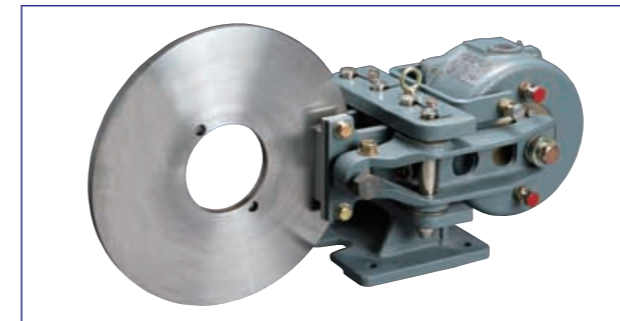

Features

- Clamping disc brake using electromagnets
- Small, lightweight, and easy to handle.

Specifications

- Braking force: 196 to 2450 N

Applications

- For hoisting, travelling, traversing and swiveling of crane, winch, lift, elevator, crusher, bending roller, conveyor, etc.

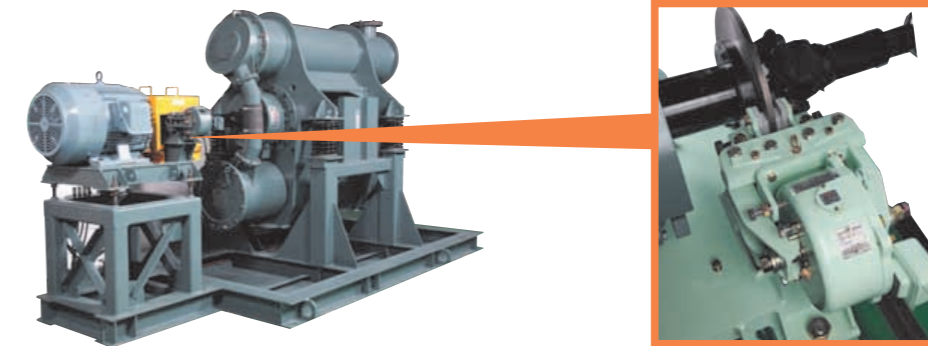

Application to Vibro Mill

Pivotal Conveyor



Features

- Horizontal and vertical transporting equipment using overlapping buckets

Specifications

- Transport capability: 3 to 40 m³/h
- Conveyor length: Up to 30 m

Applications

- Food products (sugar, coffee, etc.), pharmaceutical products, magnetic materials, activated carbon, glass fiber, etc.

HK Quick Sieve



Features

- On-site particle size measurement
- Faster and more efficient than hand sifting or a sieve shaker

Specifications

- Complies with JIS standards for Ø200 sieves.
- Uses oil-free pressurized air: ~0.55 Mpa, 40 ℓ/min

Accurate Feeder



Features

- Powders and granular materials are fed at a uniform rate, without bridging, in an oscillating resin hopper.

Specifications

- Feeding capacity: 0.045 to 26000 ℓ/h
- Flexible hopper capacity: 2 to 80 ℓ

Applications

- Uniform feeding of powders and granular materials with poor fluidity

Screw Feeder

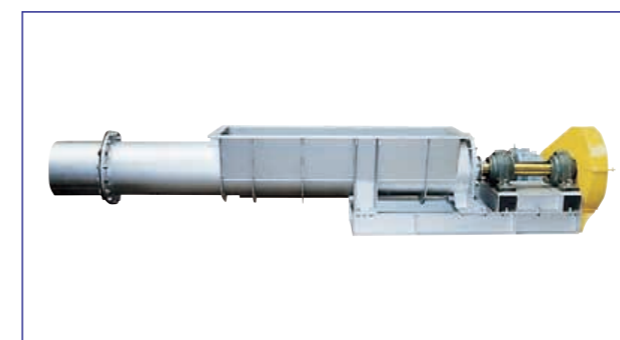

Features

- The screw shape is selected in accordance with the properties of the powder or granular material to be fed.

Applications

- Discharging of powder
- Controlled operation in combination with scale

System Application Examples

• Vibration Mill for Cleaning



Equipment

- Nickel anode cleaning equipment
- Continuous cleaning equipment using vibration mill YAMS-20

Specifications

- Processing capacity: 500 kg/h
- Water consumption: 300 ℓ/h

Applications

- Removing and washing of surface adherents from metal grains, coins, crushed glass, ceramic balls, etc.

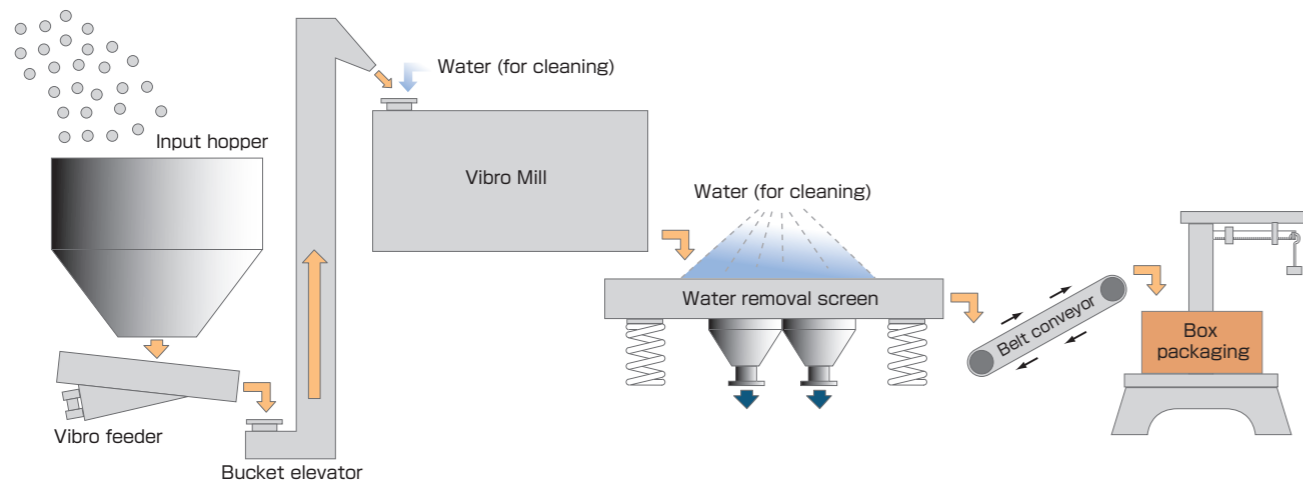

Nickel Anode Cleaning Equipment Flow Chart

Guide to Sample Testing

The Powder Engineering Center has various testers that can help with milling, classification, screening, conveying, feeding, and other needs. Our extensive record of accomplishment and our experiences allow us to propose the most appropriate tests and optimal equipment.



Flow from Request to Equipment Planning

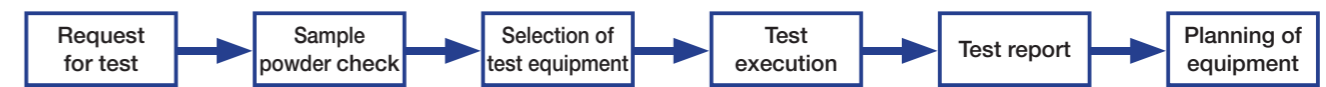

List of Test Equipment

Equipment	Name	Model
Milling machine	Vibro Pot	YAMP-6S
		YAMP-4J
	Vibro Mill	YAMT-20SNVB
		YAMH-25FN
		YAMT-20JNVD
Classifier	Micro Cut	YAMT-100FNVF
		YACA-132H
		YACA-400H
		YACA-400HS
		YACA-400V
Screener	Jumping Screen	LF-0.5-2.52/8ED
	Vibro Screen ^{*1}	SFZF-60-360B-2
Feeder		Electromagnetic Feeder
	MFW-46-90S	
	Vibro Feeder ^{*1}	MFS6-10-50S
		FD-66-220
		FD-66-220
Conveyor	Electromagnetic Multi-Conveyor	YAF-60FE
		BDF-67
	Vibro Conveyor ^{*1}	MCP-30-25L
		Vibro Lift ^{*1}
Filling machine	Vibro Packer ^{*1}	YULP-20015SWR
		Step Flow
Analyzer	Particle Size Measuring Device	VPP250F/100
		Low tap shaker
		Air jet sieve
	Specific Surface Area Meter	Micro track
		Shimadzu specific surface area measuring device
Powder Characteristics	Powder tester	
Moisture Meter	Infrared aquameter	

*1: Vibro series test equipment is installed at the Vibration Equipment Powder Engineering Center of Daito Vibration Engineering Co., Ltd.

◆ For inquiries, please contact us.